

StowAway

Tailgates By **THIEMAN**

Raising Performance to New Levels

Model ST-40

Platform in Loading/Unloading Position

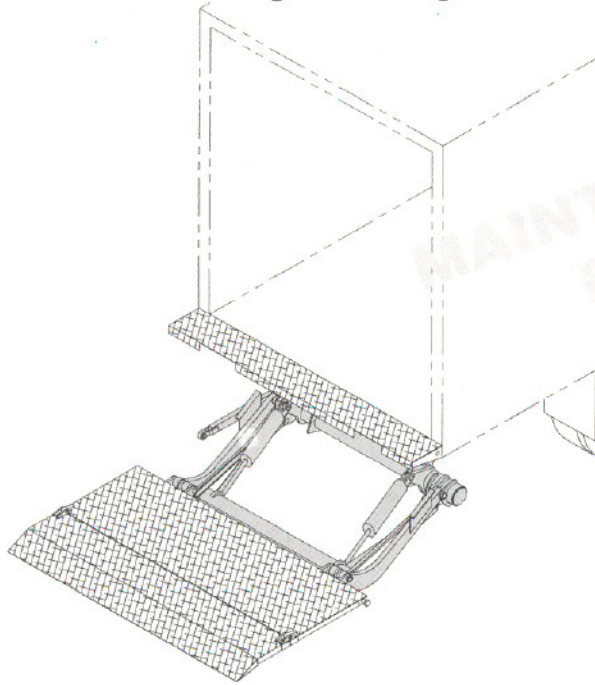

Platform in Travel Position

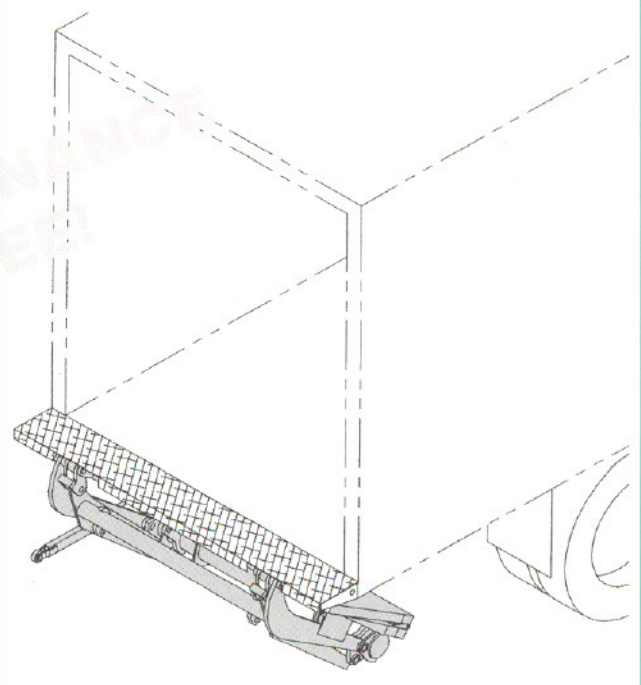

FEATURING:

- Meets TMC Electrical Guidelines
- Up to 4000 lb. Lift Capacity
- Dual Cylinder Lift
- Maintenance-Free Bearings
- Heavy-Duty Lift Frame
- 84" x 40" and 84" x 52" Platforms

Designed for handling heavy, palletized loads, the THIEMAN ST-40 continues to be the industry choice among the heavy-duty, large platform Stowaways.

With maintenance being a major concern among fleets today, Thieman has incorporated self-lubricating Teflon bearings at all pivot points. This virtually eliminates the need for maintenance.

Along with a large platform and self-lubricating bearings, is the industry's strongest lift frame, which makes the THIEMAN ST-40 the most efficient, reliable, and durable Stowaway in its class.



Features, Benefits and Specifications

Model ST-40 EST

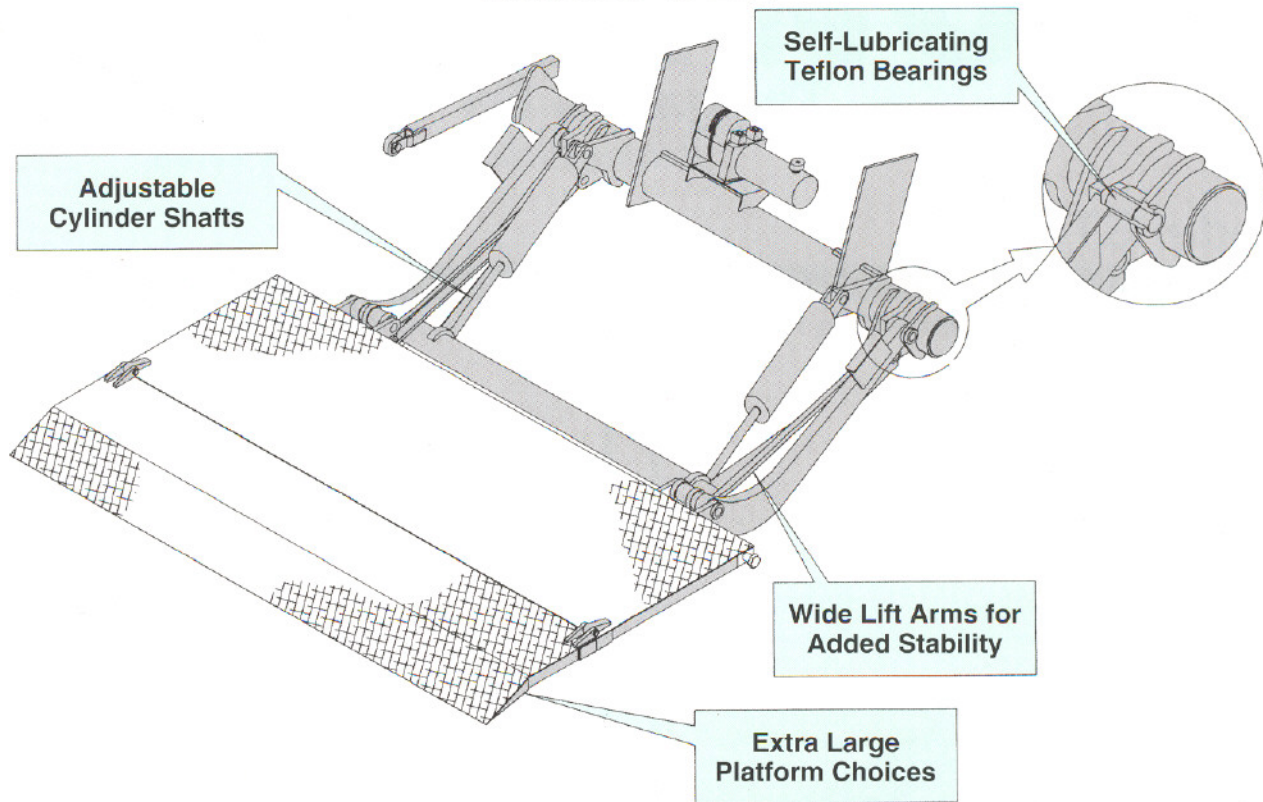

STANDARD FEATURES AND BENEFITS:

- Teflon Composite Bearings Used with Stress-Proof Pins for Virtually Maintenance-Free Operation at Pivot Points.
- No Lubrication Required at Pivot Points for Less Overall Maintenance.
- Dual Lift Cylinders for Maximum Stability.
- Adjustable Cylinder Shafts for Adjusting Platform Height.

- Adjustment Bolts for Adjusting Platform Angle.
- Meets All TMC Electrical Guidelines for Reduced Service Requirements.
- Power Up and Power Down for Better Cold Weather Operations.
- Solenoid Cover for Increased Reliability.
- Sealed Toggle Switch Control for Easy Weather Proof Operation.

- Dual Travel Latches to Secure Lift During Road Travel.
- 150 Amp Circuit Breaker for Electrical Protection.
- Snubber Kit for Reduced Movement While in Travel Position.

AVAILABLE OPTIONS FOR ST-40:

- Push Button Control
- Remote Pendant Control
- In-Cab Shut Off Switch

- Heavy Duty I-Beam Dock Bumpers
- Rear Impact Guard (FMVSS 223)
- Power Unit Enclosure

- Light Kits
- Trailer Kits
- PTO Power Source

Model #	Platform	Ramp	Load Capacity	Lowering	Approx. Install Wt.	Bed Height Range
ST 40 EST	84" X 40"	10"	4000 Lbs.	Power	1050	48" to 56"
ST 40 EST	84" X 52"	*Full Taper	3300 Lbs.	Power	1045	48" to 56"

Application: Van Bodies, Trailers and Stake Bodies

EST-Electric w/Toggle Switch Control/Power Down *Aluminum Flip-Over Wedge

Distributed By:

THIEMAN
TAILGATES INC.
Raising Performance to New Levels

600 East Wayne Street
 Celina, Ohio 45822
 Phone: 419-586-7727 or
 800-524-5210
 Fax: 419-586-9724
 www.thieman.com
 tailgates@thieman.com

THIEMAN Reserves the right to Change Products Specifications at any time Without Prior Notice.
 Printed in U.S.A. 2/03 • 2M • MP51755